

# SPUDNIK

## *Scooper* 150



# SPUDNIK

## ***Purpose***

- ***The Model 150 Telescoping Scooper has been designed to scoop and transfer potatoes from a storage facility into a conveyor system or a trans loading system***



# *Advantages*

- drop from the intake belt onto the conveyor is the lowest available in the market
- the operators working position is designed to provide a clean and unobstructed view of the potato pile and intake
- perfect balance when scooping potatoes (nose never gets airborne)
- works on both concrete and dirt floor
- only scooper available with electric drive system
- capacity up to 280 t/h (highest in the industry)



# *Standard Equipment*

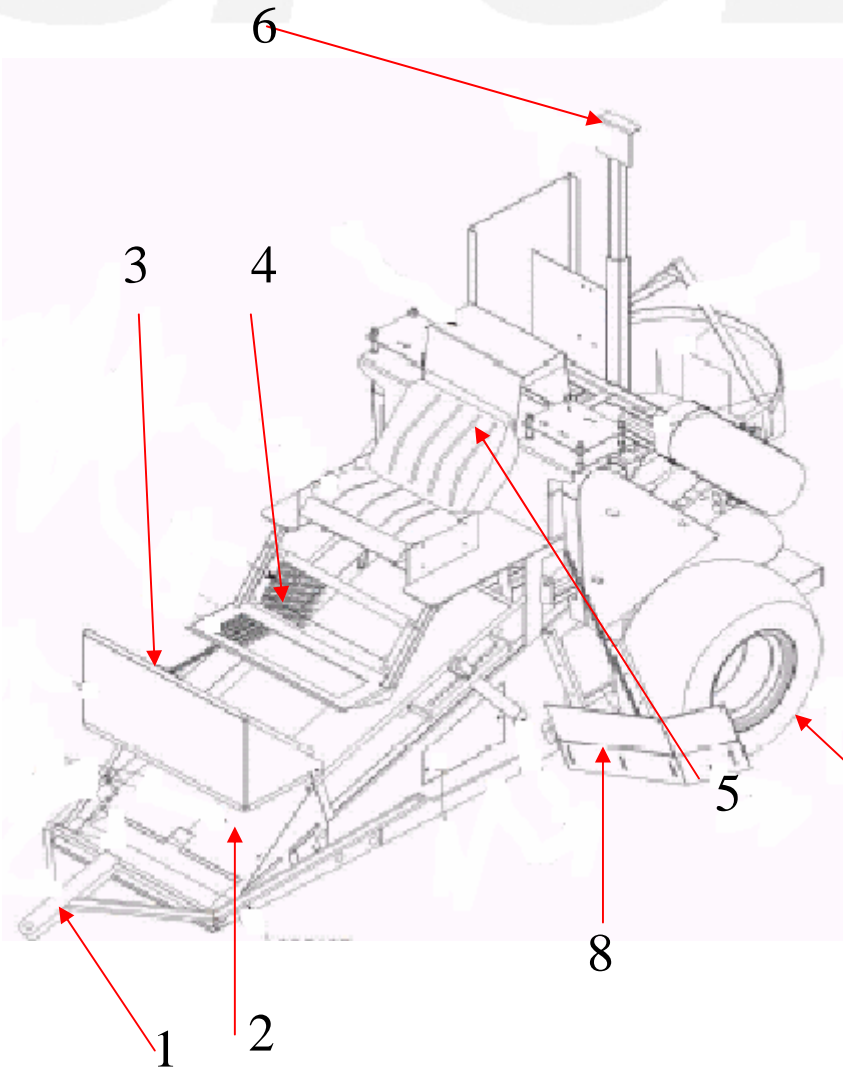

1. Front Tow Hitch
2. Scooper Nose Belt
3. Flow Control Gauge
4. Foot Rest
5. Folding Back Seat
6. 500 watt halogen light
7. Heavy duty tandem axles and wheels
8. Wing Attachment

# Options

- **Width Options** - 30" or 36"
- **Color Option** - Red, White or Other
- **Pan lift Option** – Hand Pan Lift or Actuator Pan Lift ([Picture](#))
- **Nose Belt or Chain Option** – Flat Belt, ½" Cleated Belt, Mini Cleat Lock, Rough Top Belt, or 36mm Chain
- **AC Wheel Drive Options** – STD Start or Soft Start
- **Tow Hitch Attachment** – for 30" and 36" ([Picture](#))
- **UHMW Lining** – Under Nose Attachment, Lining Sides Scooper Nose and Backend Attachment, On Slides on Backend Attachment ([Picture](#))
- **Power Options** -230V 1PH Required Amps 64.2  
-208/230 V 3PH Required Amps 34.2  
-480V 3PH Required Amps 17.1

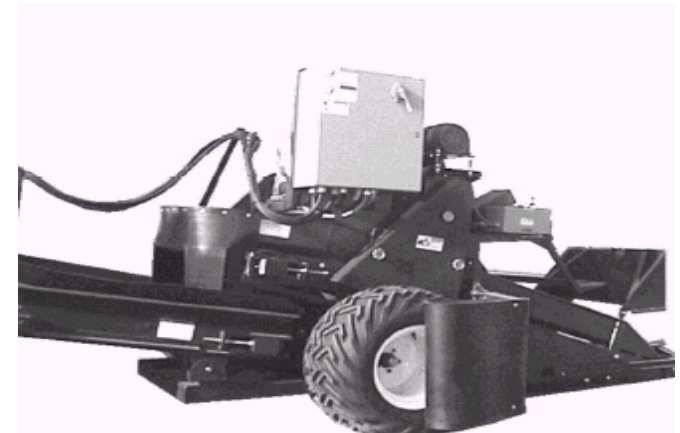

# ***Nose Skid Pan***

NOSE SKID PAN HAND ADJUST ASSEMBLY (STANDARD)

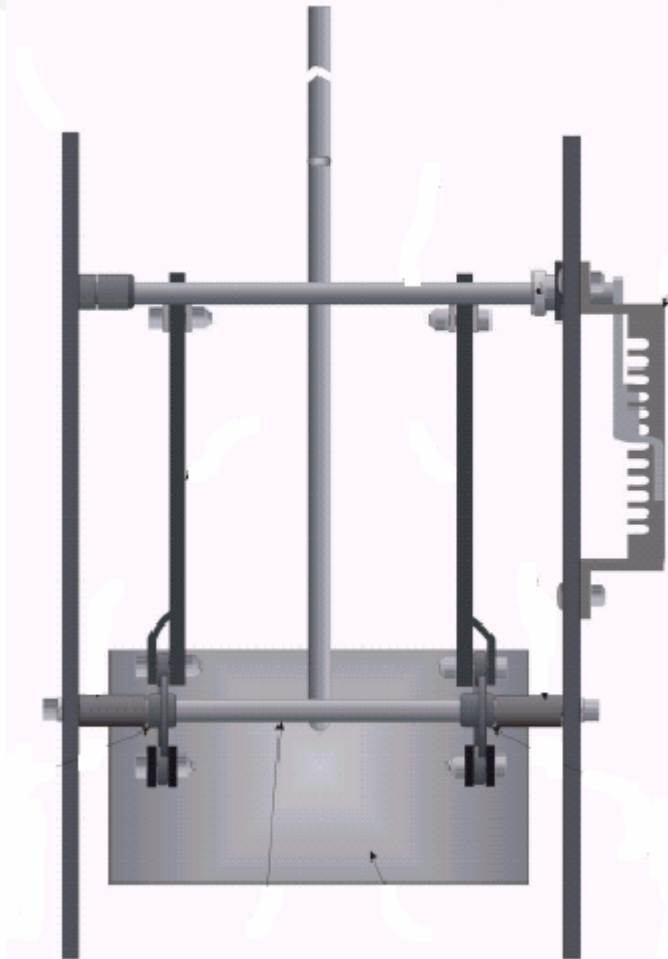

NOSE SKID PAN ACTUATOR ADJUST ASSEMBLY (OPTION)

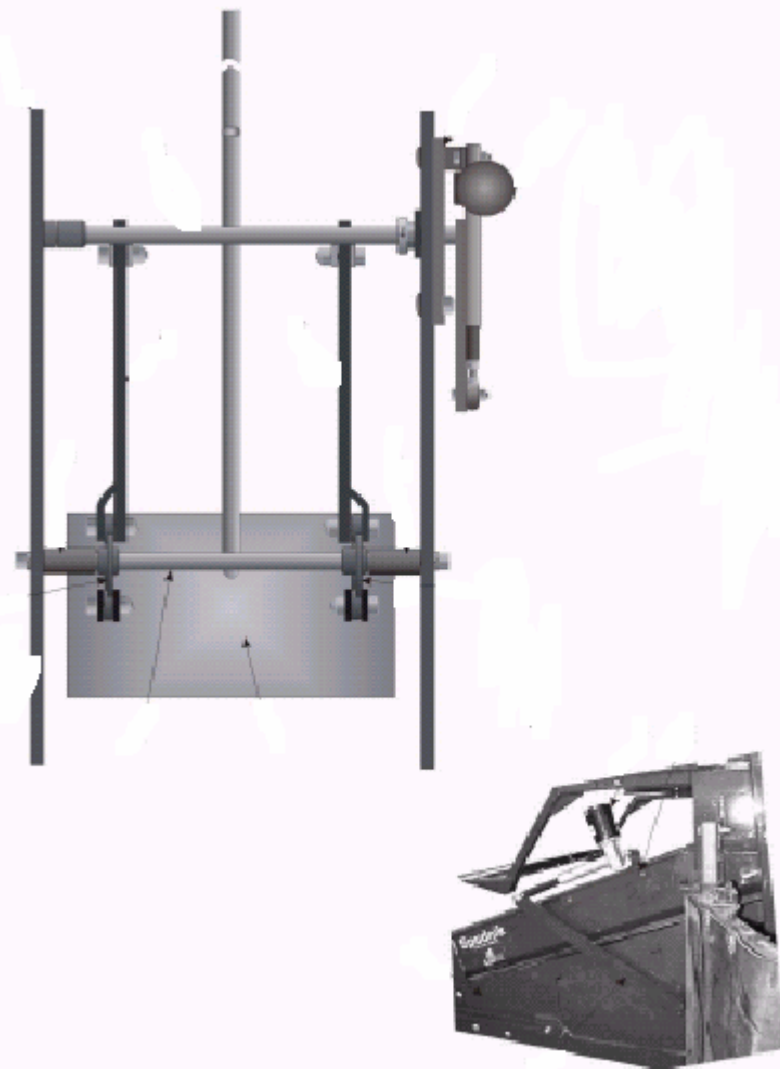

[\(Return\)](#)

# UHMW Options

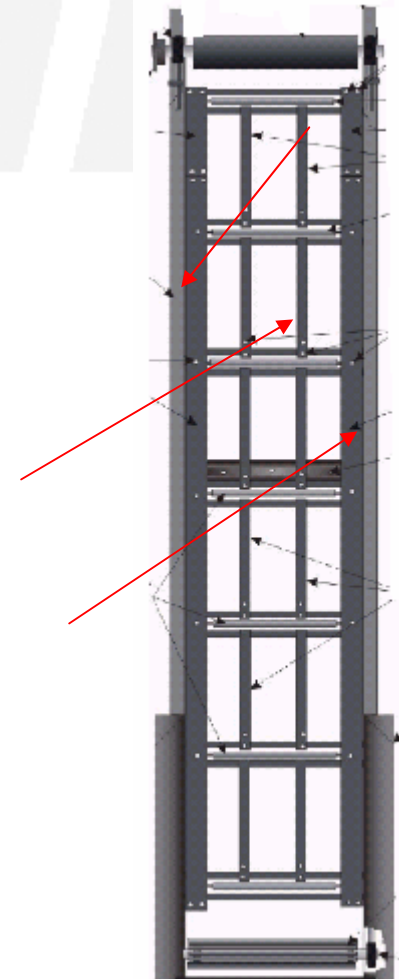
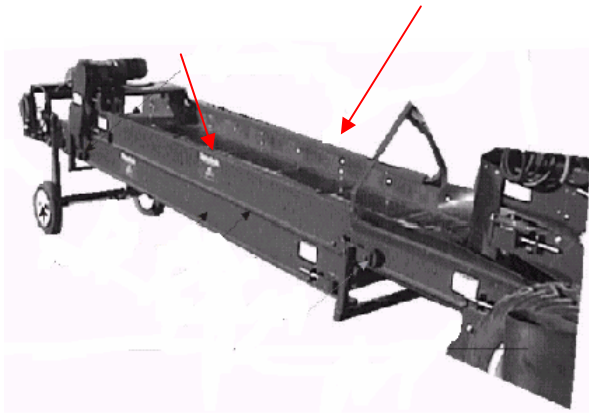

- **UHMW Lining** – *Under Nose Attachment*
  - *Lining Sides Scooper Nose and Backend Attachment,*
  - *On Slides on Backend Attachment*

[\(Return\)](#)

# *Tow Hitch and Tongue to Hang Discharge End to Piler, Eliminator, or Evenflow Bin*

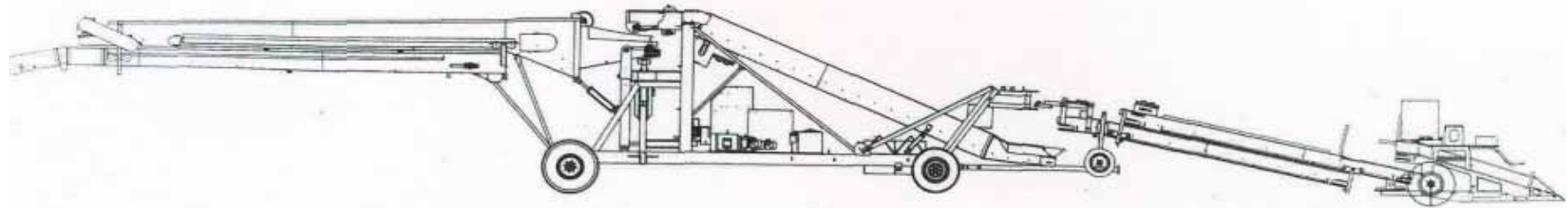

[\(Return\)](#)

# TECHNICAL SPECIFICATIONS

SCOOPER MODEL		150	
		30"	36"
Height		75"	75"
Width		62"	68"
Length		28'	28'
Length (extended)		38'	38'
Tire specifications	31x1550x15 Terra 4 ply		
Intake width		30"	36"
Belt length	Nose	18' - 3"	
	Top conv	31' - 8"	
	Btm conv	31' - 8"	
Belt width		30"	36"
Discharge height (adj.)		29"-42"	29"-42"
Capacity t/h		200	280
Available electricity	230V 1PH, 230V 3PH, 480V 3PH		
Required amperage (base machine)		64.2	34.2    17.1
Weight (base machine)		4,300 lb	4,400 lb